



Boobook Roosting Box Assembly Instructions

Thank you for purchasing a **fauNature** roosting box/artificial hollow. It is hoped the box will give you many hours of enjoyment while it provides a much-needed home to one of the many native species currently facing a "Housing Shortage".

A short video of "**Building a fauNature Nesting Box**" can be found on <https://www.youtube.com/> Simply type **fauNature** into the search box when you are in **YouTube** and you will find the video. However, it lacks the details on putting the platform perch together.

These instructions are designed to be used in conjunction with the installation brochure (please refer to our website).

Components included.

- Wooden Panels (Fig.1).
 - Side panel (fixed) – SP.
 - Back panel – BP.
 - Door panel – DP.
 - Roof – RF.
 - Base/Floor – BA.
 - Front Panel – FP.
 - Platform/Perch.
 - Bag of nest litter
- 2 x 40mm galvanised screws (for door hinging).
- 2 x 1 ¼" Nuts & Bolts (for perch).
- 1 x 60mm securing pin (for door).
- 15 x 40mm galvanised nails.
- 2 x 100mm hex head screws (not for assembly - to attach box to a tree).

Figure 1:



Additional Materials Required.

- Water-resistant wood glue.
- Electric/cordless drill and drill bits: 1) 2 mm and 2) 3.5mm.
- 40mm galvanised screws can be substituted for the 40mm galvanised nails if you prefer.

Note: If fixing the hollow with screws it is not essential to use wood glue as well. However, the glue will ensure the end product is well sealed from wind and rain. If using screws, it is important to pre-drill the holes (3.5mm bit) to ensure the screws take easily and the ply does not split. Alternatively, if you are using the nails provided, while not essential it may also be useful to pre-drill the holes (2mm bit).

Assembling the "Hollow".

1. Attaching the Side and Rear Panels.

- Place the "Side Panel" (SP) on its short edge.
- Slip the "Base" (BA) into the rebated/grooved end of the SP for stability. (Fig 2)
- Run glue along the edge of the SP (not the base).
- Place the "Back Panel" (BP) on the SP aligning their top angled edges.
- Nail the RP to the SP using 3 nails along its length - top, middle and base. (Fig 3)

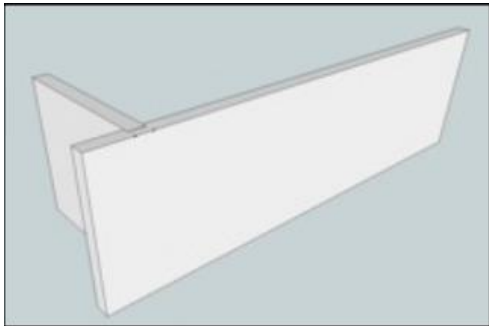

Figure 2: Support Fixed Side Panel with Base Panel, into the

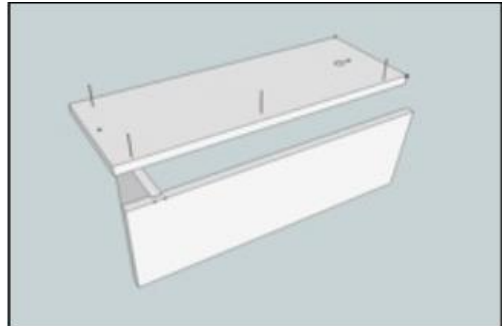

Figure 3: Attach the Rear Panel to the Fixed Side Panel.

2. Gluing the Base.

- Turn the SP/BP over so the SP is lying flat on the bench and the BP is to the rear.
- Remove the BA.
- Run glue along the rebate in the SP and one of the two long edges of the BA.
- Place one of the short edges of the BA in the rebate, with its glued longer edge towards the BP.
- Push the BA up to the BP, approximately parallel to the bottom edge. (Fig 4)

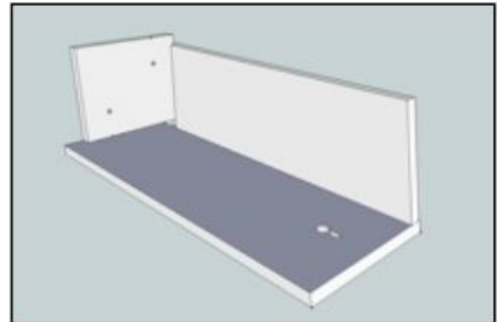

Figure 4: Slide the Base Panel into the rebate in the Fixed Side Panel, flush with the rear Panel.

3. Attaching the Front Panel.

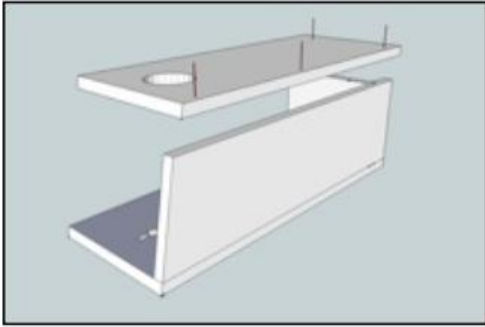

Figure 5: Fix Front Panel to the Fixed Side & Base Panels.

- Back to the main box, flip the assembled components so the BP is now flat on the bench and the SP is towards the front of the bench.
- Run glue along the top BA and SP edges.
- Place the FP on the SP/BA aligning the top angled edge of the FP with the SP.
- Nail the FP to the SP using 3 nails along the length - top, middle and base. (Fig 5)

4. Nailing the Base.

- Place the "Door" panel (DP) between the FP and BP to complete the box.
- Make sure the BA runs parallel to the base of the FP and is pushed into the rebate so that the DP is flush with the side of the

FP.

- Drive a nail through the FP and into the BA ~ 40mm in from the door edge to affix the FP to the BA.
- Turn the box over (with the door still in place).
- Repeat the process outlined above - aligning the DP with the BP and nailing the BP to the BA - 40mm in from the door edge.

5. Adding the Roof.

- Stand the box on its base.
- Glue around the top edges of the BP, SP & FP.
- Align the Roof (RF) with the other top edges of the BP, SP & FP and push into place.
- Make sure the RF and the edge of the FP are flush, then nail the RF to the FP ~20mm in from the DP edge.
- Nail the RF to the RP ~ 20mm in from the SP edge, repeat this process with the RF to the FP.
- Nail the RF to the centre of the SP.
- Finally, while applying pressure to the RP, to achieve a snug fitting door, nail the RF to the RP ~20mm in from the DP edge (Fig.6).

Fig 6 Fix Roof Panel to Front, Rear and Fixed Side Panels. Rix door using hinging screws

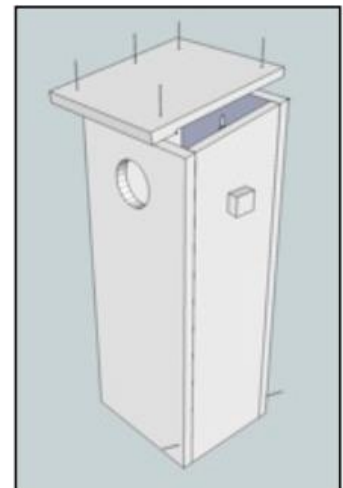

6. Securing the Door.

- Turn the box on its side so the DP is upper most and align the DP leaving 0.5-1.0mm space at the top (this will enable the door to open and close without sticking).
- Turn the box so it is resting on its BP and drill a 3.5mm hole 7mm from the edge and 20mm up from the base of the FP on the DP side.
- Screw in the 40mm galvanised screw so it is nearly flush with the BP.
- Turn the box over so it is resting on the FP.
- Repeat the above step drill a 3.5mm hole 7 mm from the edge and 30 mm up from the base of the BP on the DP side.
- Screw in the 40 mm galvanized screw so it is nearly flush with the BP.
- Drill a 1/8" hole 7mm in from the edge and 60mm down from the top of the FP on the DP side. Trick: angle the hole slightly down rather than level.
- Slide in the Securing Pin to hold the door closed.

7. Attaching the Platform/Perch.



- Push the bolts through the predrilled holes from inside the box and through the platform, so washer and nut are outside, then tighten.

- Assembly is now complete. Set the box aside for the glue to dry, firstly removing the securing pin and ensuring the door is slightly ajar, so it is not fixed in place by any excess glue displaced while attaching the roof.

Leave the hollow to dry for at least 24 hours.

Painting the "Hollow".

There are a number of options in painting the "Hollow". You can use either outdoor timber/furniture oil or a water-based emulsion/paint.

Lanotec™ is the most environmentally friendly product identified to date, however Tung Oil based products can also be used. The benefit of using these products is that they are amongst the most environmentally friendly available and look natural. However, reapplication is likely to be required every 12-24 months to ensure the "Hollow" continues to be protected from the elements.

Water based paints are also a reasonable treatment option. Products like Cabot's® TimberColour® or Watty's® Solagard® are amongst the more environmentally friendly paints available. The benefit of these is a range of colours, though pales, muted colours are typically used (greens, greys or browns), and that an initial application (typically two coats - following manufacturer's instructions) is likely to last for the life of the box.

Allow the "Hollow" to dry as per the manufacturer's instructions. Remember to dry the box with the door ajar, so it does not stick. Once dry the box can provide much needed habitat.

Congratulations!! The box can be installed at your leisure – following the installation brochure guidelines (please refer to our website).

Further information.

If you require further information, please visit the *fauNature™ website* or contact us.



Any feedback to help us provide the products or services you may be looking for is most welcome
© 2022.